

**Prostore 500**  
**2½ Door Digital Refrigerator, 470lt, dual**  
**temperature (0+10°C/0+10°C) - Remote**

ITEM # \_\_\_\_\_

MODEL # \_\_\_\_\_

NAME # \_\_\_\_\_

SIS # \_\_\_\_\_

AIA # \_\_\_\_\_

**691373 (PS04RRIFR)**

 2-½ door, dual temperature  
 prostore Cabinet 470lt,  
 0+10°/0+10°C°, AISI 304,  
 remote

### Short Form Specification

**Item No.** \_\_\_\_\_

Two half door refrigerator mainly constructed in 304 AISI stainless steel with external bottom panel in anti-corrosive material. Large digital display featuring humidity selection button (3 preset level), cabinet temperature display and setting and turbo frost cycle (to rapidly cool warm loads). HACCP-compliant control with alarms and history. Frost Watch Control to defrost only when required with automatic evaporation of defrost water. Optimized airflow provides even temperature distribution on all grids. Fitted with 65 mm-thick polyurethane insulating foam. Self-closing, on-site reversible door features microswitch to switch off the fan when the door is opened. Remote refrigeration unit (not included). Built-in refrigeration unit; ventilated operation; Interior LED light. For ambient temperatures up to 43 °C. CFC and HCFC free.

Supplied with 4 x 520X442mm plastic coated grids and n 4 pair of grid runners. Prearranged to fit RS485 port to facilitate connection to a remote computer and integrated HACCP systems.

### Main Features

- Large digital white-digit display with humidity selection button (3 preset level), cabinet temperature display and setting and turbo frost cycle (to rapidly cool warm loads).
- IPX5 frontal water protection.
- Fully compliant HACCP digital control: when temperature exceeds critical limits, acoustic and visual alarms are activated. Up to two months of event are kept in memory.
- Large storage area suitable to contain 520x442 mm grids or shelves to improve net capacity.
- Optimized airflow within the chamber guarantees uniformity of temperature on all grids.
- Greater storage space: internal structure with numerous charging positions available to host grids, ensuring higher net capacity.
- Model requires only 1 phase 230V/50Hz supply and can be plugged straight into an existing power socket.
- Prearranged to fit RS485 port to facilitate connection to a remote computer and integrated HACCP systems.
- Complies with main international certification bodies and is CE marked.
- Self closing and on site reversible left/right doors.
- Prearranged for remote alarm.
- Two half doors.
- Dual temperature type: 0 +10 °C/ 0 +10 °C.
- Solenoid and thermostat assembled.
- Connectivity ready for real time access to connected appliances from remote and data monitoring (requires optional accessory).

**APPROVAL:** \_\_\_\_\_

## Construction

- Stainless steel AISI 304 external panels (galvanized external back).
- Inner cell with rounded corners, bottom pressed in only one piece.
- Stainless steel runners and supports easily disassembled.
- Internal components removable without the use of tools to facilitate cleaning operations.
- Pressed stainless steel door handle without joints gathering dust and dirt.
- Easy access to the main components for maintenance.
- Developed and produced in ISO 9001 and ISO 14001 certified factory.
- Heated door frame.
- Lockable door.

## Sustainability



- Removable triple-chamber balloon magnetic gasket to improve insulation and reduce energy consumption and ease of cleaning.
- Frost Watch Control: fully automatic defrost starts only when ice is actually building-up in the evaporator and adapt the defrosting duration to guarantee perfect ice removal while optimizing energy efficiency consumption.
- Optical door microswitch to stop the fan once the door is opened, thus minimizing energy waste.
- Interior LED light to save energy and for best internal visibility.
- CFC and HCFC free (ecological refrigerant type: R404a, gas in foam: cyclopentane).
- Cleaning-free condenser: the structure of the wire frame condenser prevents dust and grease accumulation thus avoiding periodical cleaning operations and reducing energy consumption.

## Included Accessories

- 4 of Pair of runners for GN 2/1 grids, for PNC 880320 prostore cabinets
- 4 of Rilsan-coated grid 520x442mm for PNC 880342 Prostore 470l

## Optional Accessories

- |   |            |                          |
|---|------------|--------------------------|
| • Pair of runners for GN 2/1 grids, for prostore cabinets | PNC 880320 | <input type="checkbox"/> |
| • Stainless steel grid (520x442)                          | PNC 880321 | <input type="checkbox"/> |
| • Pedal opening for cabinets                              | PNC 880324 | <input type="checkbox"/> |
| • Kit 4 feet, height 200mm                                | PNC 880325 | <input type="checkbox"/> |
| • Kit of 4 feet-h=67 (marine)                             | PNC 880326 | <input type="checkbox"/> |
| • Kit pair of runners (marine)                            | PNC 880327 | <input type="checkbox"/> |
| • Base frame for 1/1 GN rack for 470lt prostore           | PNC 880328 | <input type="checkbox"/> |
| • Rilsan-coated grid 520x442mm for Prostore 470l          | PNC 880342 | <input type="checkbox"/> |

Front

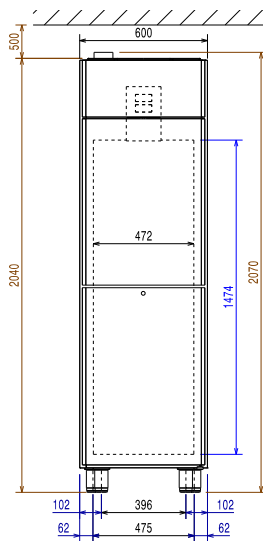

Side

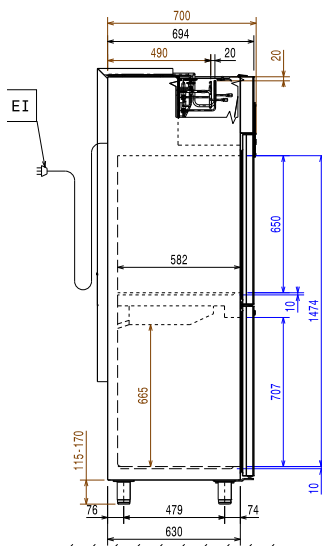

EI = Electrical inlet (power)  
 RI = Refrigerant Inlet  
 RO = Refrigerant Outlet

Top

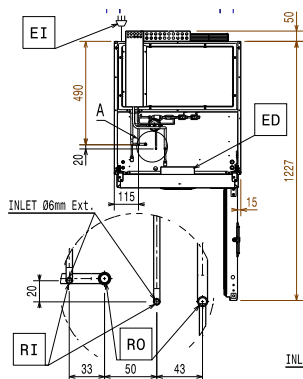
**Electric**

**Supply voltage:**  
 691373 (PS04RR1FR) 220-240 V/1 ph/50/60 Hz  
**Electrical power max.:** 0.32 kW

**Key Information:**

**Gross capacity:** 470 lt  
**Door hinges:** 2 Right  
**External dimensions, Width:** 600 mm  
**External dimensions, Depth:** 741 mm  
**External dimensions, Depth with Doors Open:** 1226 mm  
**External dimensions, Height:** 2070 mm  
**Number and type of doors:** 2x1/2 Full  
**Internal Dimensions, Width:** 472 mm  
**Internal Dimensions, Depth:** 582 mm  
**Internal Dimensions, Height:** 1474 mm  
**Height adjustment:** 15/40 mm  
**Number and type of grids (included):** 4 - 520x442  
**Type of external material:** 304 AISI  
**Type of internal material:** 304 AISI

**Refrigeration Data**

**Control type:** Digital  
**Condensation temperature:** 55 °C  
**Refrigeration type:** R404A;R452A  
**Defrost type:** Automatic  
**Suggested refrigeration power:** 278 W  
**Suggested refrigeration power: (second unit):** 278 W  
**Condition at evaporation temperature:** -10 °C  
**Condition at condensation temperature:** 55 °C  
**Condition at ambient temperature:** 43 °C  
**Connection pipes (remote) - outlet:** 9.5 mm  
**Connection pipes (remote) - inlet:** 6 mm

Ref. Power calculated at a linear distance of 15 mt (piping), according to ASHRAE32 conditions

\*Note:

**ISO Certificates**

**ISO Standards:** ISO 9001; ISO 14001; ISO 45001; ISO 50001

**Sustainability**

**Refrigerant type:**